

Welcome to the Mamba Pedals Bearing and Axle Replacement Guide

Before beginning the maintenance on Mamba pedals, ensure a seamless process by utilizing high-quality tools to avoid damaging the screw sockets. It's advisable to service your pedals one side at a time to avoid mixing up parts. Additionally, be mindful of thread directions, as indicated by diagrams on both sides of the pedal, and pay special attention when handling these specific parts.

NEW AXLE KIT

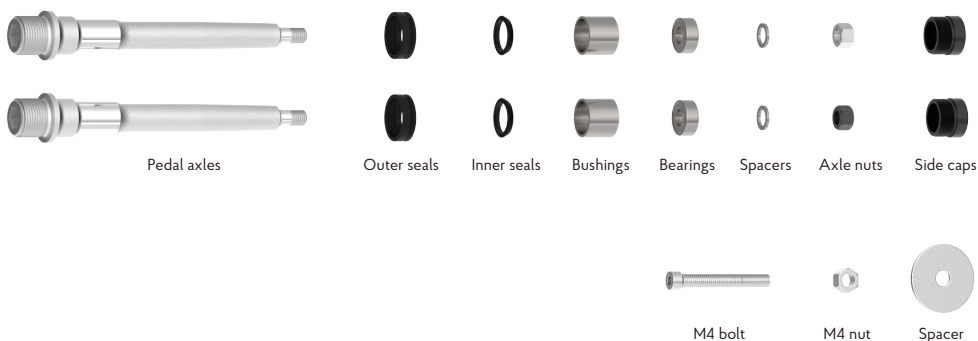

TOOLS REQUIRED

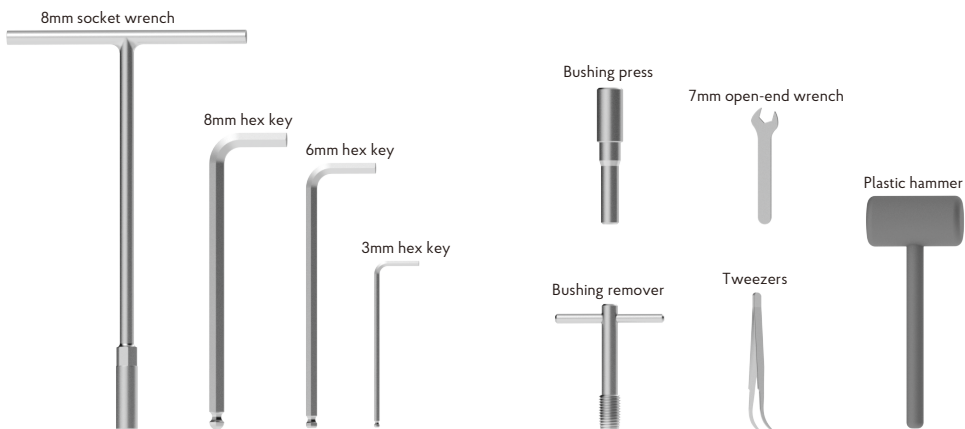

STEP 1: Remove the side cap using a 6mm hex key.

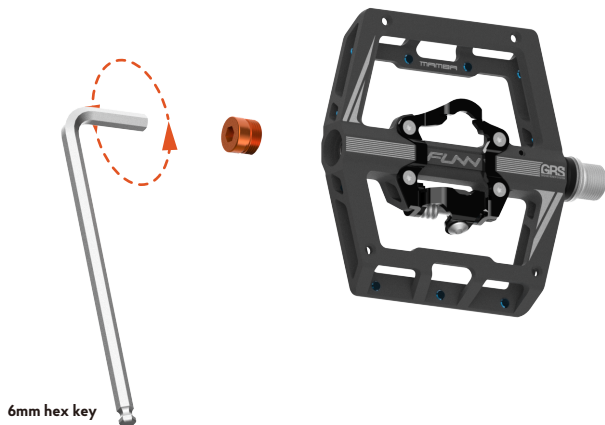

STEP 2: Secure the axle with an 8mm hex key, then use an 8mm socket wrench to loosen the axle nut. Be aware of the thread direction on each side of the pedal.

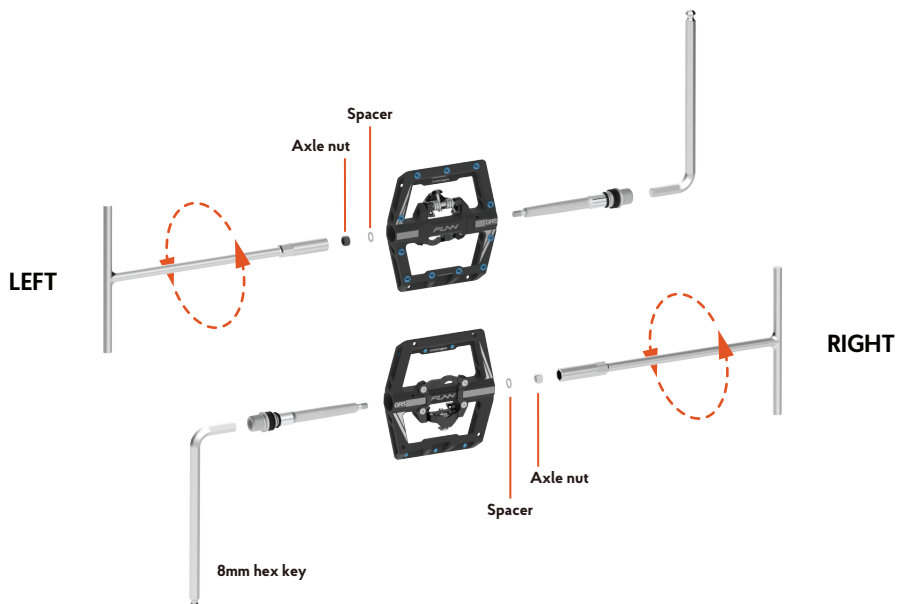

STEP 3:

Inside the axle bore, you'll find an inner seal. Use tweezers to gently remove it.



STEP 4:

To extract the bearing from inside the pedal, start by inserting an M4 bolt into the pedal body with a 3mm hex key. Then, fit a washer and M4 nut onto the M4 bolt.

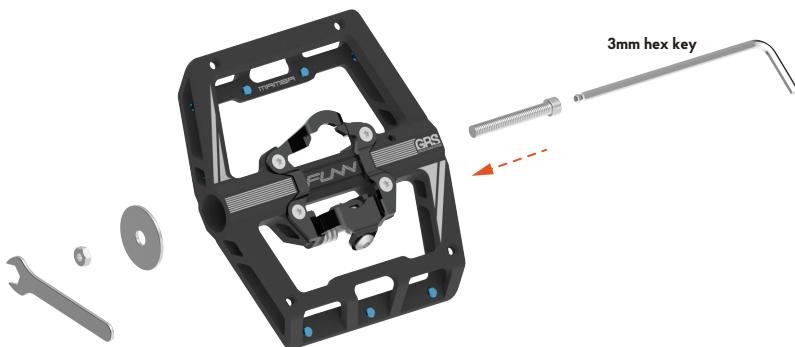

STEP 5:

Secure the M4 nut with a 7mm open-end wrench, and use the 3mm hex key to tighten the M4 bolt. Continue tightening the M4 bolt until the bearing is extracted.

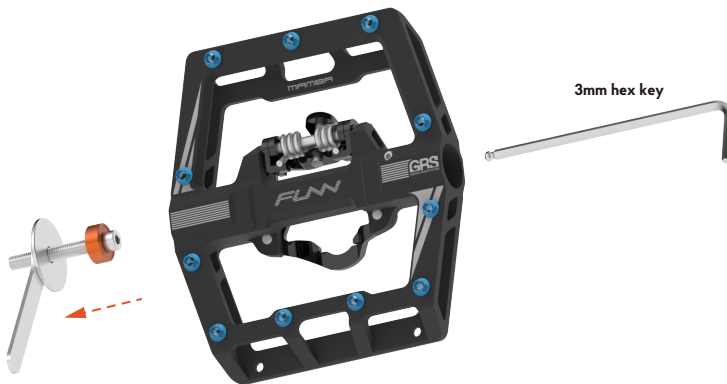
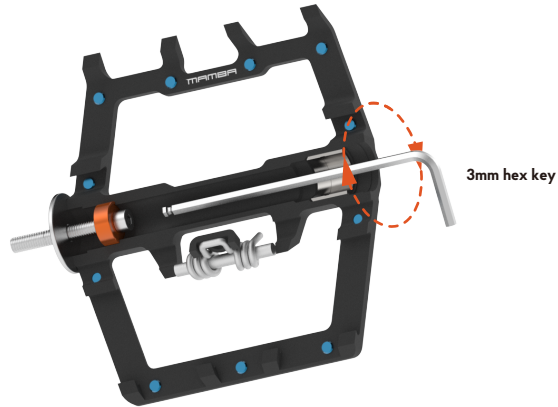

STEP 6:

To extract the bushing from the pedal body, secure the pedal body in a vise. It's advisable to place a cloth between the pedal body and the vise to protect the pedal's surface.

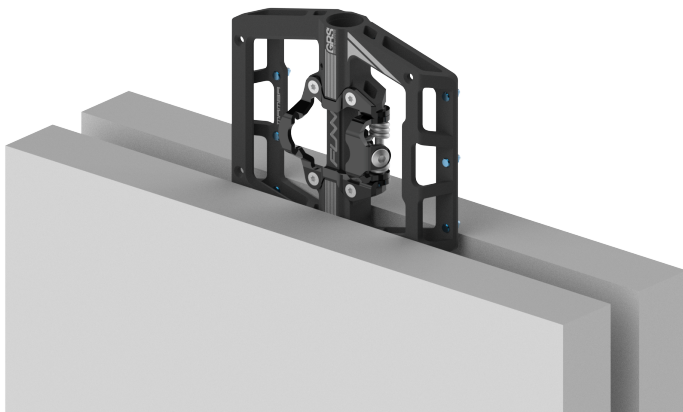

STEP 7:

Push and screw the bushing remover tool into the bushing within the pedal body. Once the remover is fully engaged with the bushing, pull it out to remove the bushing.

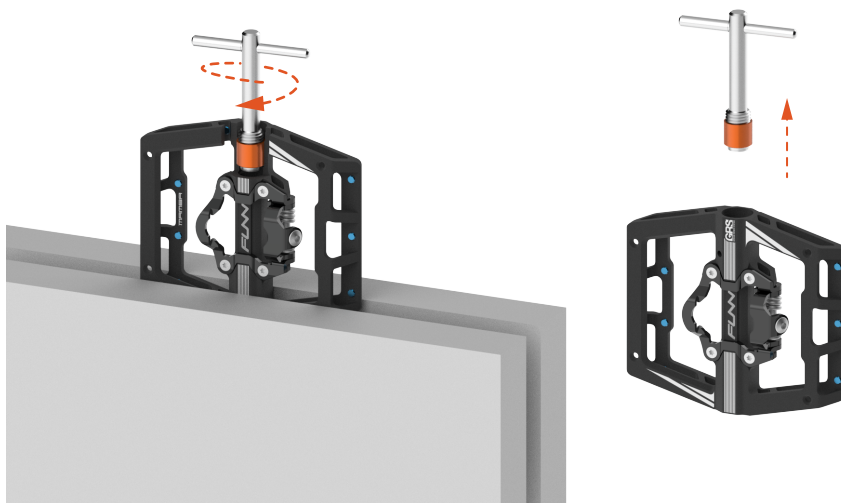

STEP 8:

Position the new bushing on the bushing press. Then, gently tap the bushing press with a plastic hammer to install the new bushing.

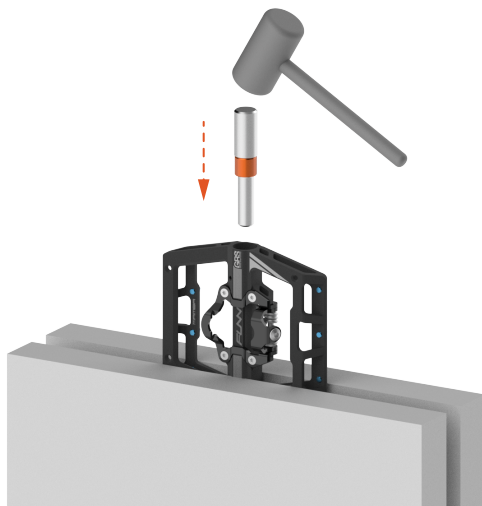

STEP 9:

Apply grease on the interface between the side cap and the bearing's outer race. Push the new bearing into the pedal by tightening the side cap into the pedal. Make sure the side cap absolutely bottoms out to make sure the bearing is properly seated.

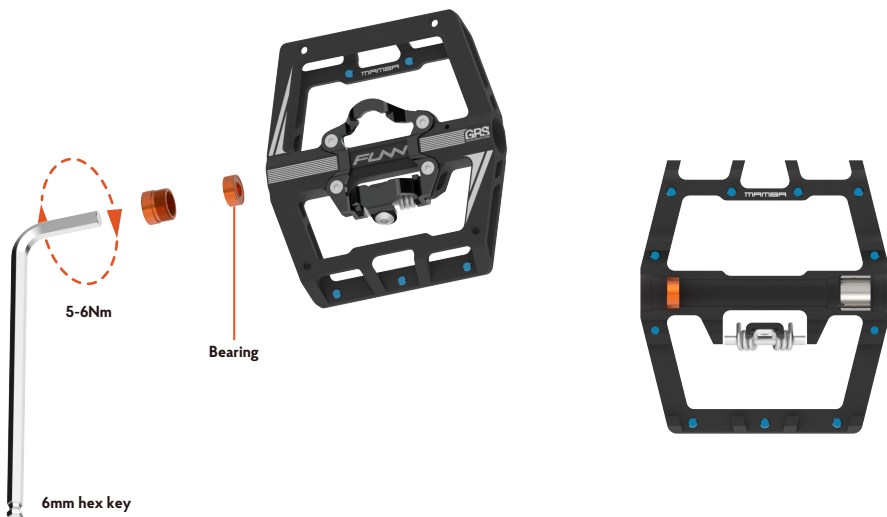

STEP I:

Identify the left and right-hand side axles. The left-side axle has a lathed mark on the axle head, whereas the right-side pedal has no markings. Fit the new outer and inner seals onto the axle, paying attention to the orientation of the seals. Then, apply grease to the areas of the axle that come into contact with the bearing and bushing.

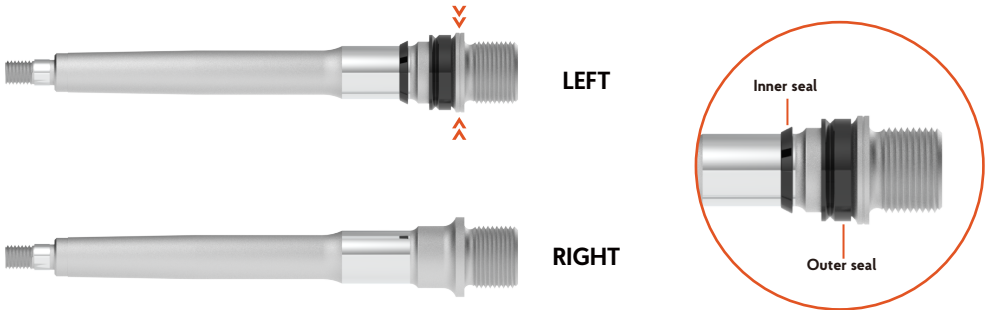

STEP II:

Insert the pedal axle into the pedal body, holding the axle head steady with an 8mm hex key. Next, tighten the axle nut using an 8mm socket wrench. Remember, the silver nut corresponds to the right side axle, while the black nut is designated for the left side axle. It's important to note that the thread directions differ on each side of the pedals. After securely fastening the nut, ensure the pedal body pivots smoothly and without any resistance.

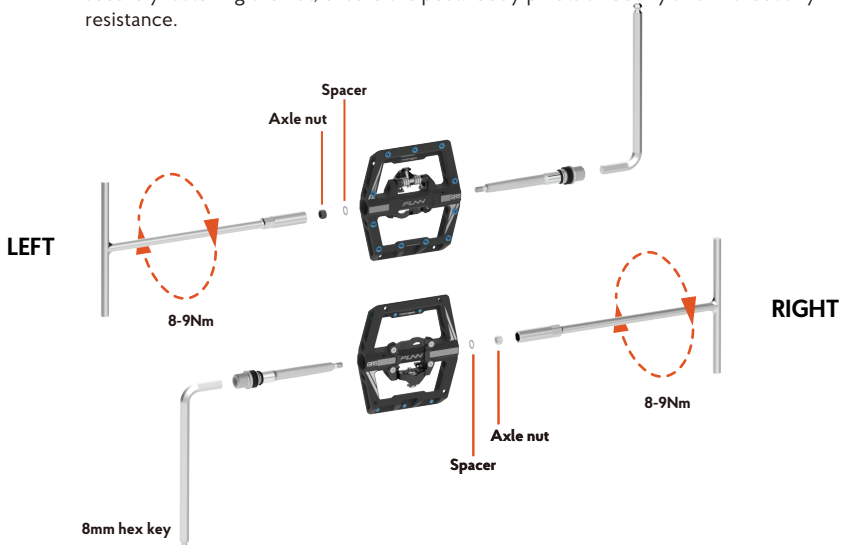

STEP 12:

Reattach the side cap using a 6mm hex key. After installation, check that the axle rotates smoothly and is free from any side-to-side movement.

